

## High function/High performance PID control

### ■ Features

#### ● Upgrade functions(★)

#### ★ Convenient parameter setting (by DAQMaster)

##### - Parameter mask

Hides unnecessary and seldom used parameters

##### - User parameter group

Groups usually used parameters to set parameters fast and conveniently

#### ★ Line-up Alarm output3(heating&cooling OUT2 Relay output model), transmission output 2 (transmission output model)

- Super high-speed sampling cycle (10 times faster compared to previous models)  
: 50ms sampling cycle and  $\pm 0.3\%$  display-accuracy.
- Improved visibility with wide display part and high luminance LED
- High performance controlling with heating/cooling control and automatic/manual control modes.
- Communication function supported: RS485 (Modbus RTU)
- Allows parameter setting by USB port of PC.  
: Free download the integrated device management program(DAQMaster)  
× Communication converter, sold separately.  
: SCM-WF48(Wi-Fi to RS485/USB communication converter, available soon), SCM-US(USB to Serial converter), SCM-38I(RS-232C to RS485 converter), SCM-US48I(USB to RS485 converter)
- SSR drive voltage output / Current output selectable.
- SSRP output (standard/phase/cycle control selectable)
- Heater burn-out alarm (CT input) (except TK4SP) (×CT, sold separately: CSTC-E80LN, CSTC-E200LN)
- Multi SV setting function (Max. 4) - selectable via digital input terminals.
- Mounting space saving with compact design.  
: downsized by approx. 38%(60mm) in depth compared to previous models.  
× Terminal cover, sold separately: R□A-COVER(except TK4N, TK4SP)
- Multi input / Multi range



Be sure that (★) marks are for upgraded functions.

 Please read "Caution for your safety" in operation manual before using.



### ■ Manual

- Visit our website ([www.autonics.com](http://www.autonics.com)) to download user manual and communication manual.
- User manual describes for specifications and function, and communication manual describes for RS485 communication (Modbus RTU protocol) and parameter address map data.

### ■ Integrated device management program(DAQMaster)

- DAQMaster is a integrated device management program. It is available for parameter setting, monitoring, and user parameter group setting, parameter mask setting for only TK4 Series.
- Visit our website ([www.autonics.com](http://www.autonics.com)) to download user manual and integrated device management program.

< Computer specification for using software >

Item	Minimum requirements
System	IBM PC compatible computer with Intel Pentium III or above
Operating system	Microsoft Windows 98/NT/XP/Vista/7
Memory	256MB or more
Hard disk	More than 1GB of free hard disk space
VGA	1024×768 or higher resolution display
Others	RS-232 serial port(9-pin), USB port

< DAQMaster screen >



# High Accuracy Standard PID Control

## Ordering information

TK	4	S	1	4	R	R					
Item	Digit	Size	Option input/output <sup>※1</sup>	Power supply	OUT1 control output <sup>※2</sup>	OUT2 control output <sup>※3</sup>					
						Standard	N	None ※Select in case of standard control(Heating or Cooling)			
						Heating & Cooling	R	Relay output			
							C	Current output+SSR drive voltage output			
						R		Relay output			
						S		SSRP output			
						C		Current output+SSR drive voltage output			
						4		100-240VAC 50/60Hz			
						(★)	N	SP	1	Standard	Alarm output1+CT input <sup>※4</sup>
									Heating&Cooling	Alarm output2 <sup>※5</sup>	
									2	Standard	Alarm output1+Alarm output2
									D	Standard	Alarm output 1+Digital input(DI-1, DI-2)
									Heating&Cooling	Digital input(DI-1, DI-2)	
									R	Standard	Alarm output1+Transmission output
									Heating&Cooling	Transmission output	
T	Standard	Alarm output1+RS485 communication output									
Heating&Cooling	RS485 communication output										
1		Alarm output1									
2		Alarm output1+Alarm output2									
R		Alarm output1+Transmission output									
T		Alarm output1+RS485 communication output									
A		Alarm output1+Alarm output2+Transmission output									
B		Alarm output1+Alarm output2+RS485 communication output									
(★)	N	SP	N	DIN W48×H24mm							
			SP	DIN W48×H48mm(11pin plug type) <sup>※6</sup>							
			S	DIN W48×H48mm(Terminal block type)							
			M	DIN W72×H72mm							
			W	DIN W96×H48mm							
			H	DIN W48×H96mm							
L	DIN W96×H96mm										
4		9999(4digit)									
TK		Temperature / Process Controller									

※1: In case of TK4N, TK4SP, option output may be limited due to number of terminals.

※2: In case of OUT1 control output, 'S' is able to SSR standard/cycle/phase control by SSRP voltage output as the voltage output model.  
'C' is able to select one between current output or SSR drive(standard) voltage output.

※3: Select 'R' or 'C' type which has OUT2 control output to use heating&cooling control. Select 'N' type which does not have OUT2 control output to use standard control.

※4: (★) CT input of TK4N is available only for the standard model which has alarm output1.

※5: (★) The heating&cooling model of TK4N-1□□□ has only alarm output 2.

※6: Sockets for TK4SP (PG-11, PS-11) are sold separately.

(A)	Photo electric sensor
(B)	Fiber optic sensor
(C)	Door/Area sensor
(D)	Proximity sensor
(E)	Pressure sensor
(F)	Rotary encoder
(G)	Connector/Socket
(H)	Temp. controller
(I)	SSR/ Power controller
(J)	Counter
(K)	Timer
(L)	Panel meter
(M)	Tacho/ Speed/ Pulse meter
(N)	Display unit
(O)	Sensor controller
(P)	Switching mode power supply
(Q)	Stepper motor& Driver&Controller
(R)	Graphic/ Logic panel
(S)	Field network device
(T)	Software
(U)	Other

# TK Series

## ■ Specifications

Series	TK4N(★)	TK4SP	TK4S	TK4M	TK4W	TK4H	TK4L
Power supply	100-240VAC 50/60Hz						
Allowable voltage range	90 to 110% of rated voltage						
Power consumption	Max. 6VA	Max. 8VA					
Display method	7 Segment (PV: red, SV: green), Other display part (green, yellow, red) LED method						
Character size	PV(W×H)	4.5×7.2mm	7.0×14.0mm	9.5×20.0mm	8.5×17.0mm	7.0×14.6mm	11.0×22.0mm
	SV(W×H)	3.5×5.8mm	5.0×10.0mm	7.5×15.0mm	6.0×12.0mm	6.0×12.0mm	7.0×14.0mm
Input type	RTD	JPt100Q, DPt100Q, DPt50Q, Cu100Q, Cu50Q, Nikel 120Q (6 types)					
	Thermocouple	K, J, E, T, L, N, U, R, S, B, C, G, PLII (13 types)					
	Analog	Voltage: 0-100mV, 0-5V, 1-5V, 0-10V (4 types) / Current: 0-20mA, 4-20mA (2 types)					
Display accuracy	RTD	<ul style="list-style-type: none"> <li>At room temperature(23°C±5°C): (PV ±0.3% or ±1 °C, select the higher one) ±1digit ※1</li> <li>Out of room temperature range: (PV ±0.5% or ±2 °C, select the higher one) ±1digit</li> <li>※In case of TK4SP Series, ±1°C will be added.</li> </ul>					
	Thermocouple						
	Analog	At room temperature(23°C±5°C): ±0.3% F.S. ±1digit, Out of range of room temperature: ±0.5 °C% F.S. ±1digit					
	CT input	±5% F.S. ±1digit					
Control output	Relay	OUT1, OUT2: 250VAC 3A 1a					
	SSR	11VDC±2V 20mA Max.					
	Current	DC4-20mA or DC0-20mA selectable (load 500Q Max.)					
Alarm output	Relay	AL1, AL2 Relay: 250VAC 3A 1a ※TK4N AL2: 250VAC 0.5A 1a(Max.125VA), TK4SP has only AL1.					
Option output	Transmission	DC4-20mA (load 500Q Max., Accuracy: ±0.3% F.S.)					
	Communication	RS485 communication output (Modbus RTU)					
Option input	CT input	0.0-50.0A(primary heater current value measuring range) ※CT ratio = 1/1000 (except TK4SP)					
	Digital input	<ul style="list-style-type: none"> <li>Contact Input: ON - Max. 2kQ, OFF - Min. 90kQ</li> <li>Non-contact Input: ON - Residual votage max. 1.0V, OFF - Leakage current max. 0.1mA</li> <li>Outflow current: Approx. 0.5mA</li> <li>※TK4S/M-1EA(Due to limited terminals), TK4N/H/W/L-2EA(except TK4SP)</li> </ul>					
Control type	Heating,cooling	ON/OFF, P, PI, PD, PID control					
	Heating&cooling						
Hysteresis	Thermocouples / RTD: 1 to 100 °C/°F (0.1 to 100.0°C/°F) variable •Analog: 1 to 100digit						
Proportional band (P)	0.1 to 999.9°C/°F (0.1 to 999.9%)						
Integral time (I)	0 to 9999 sec.						
Derivative time (D)	0 to 9999 sec.						
Control period (T)	0.1 to 120.0 sec.(※relay output and SSR drive output only)						
Manual reset value	0.0 to 100.0%						
Sampling period	50ms						
Dielectric strength	2,000VAC 50/60Hz for 1min. (between power source terminal and input terminal)						
Vibration	0.75mm amplitude at frequency of 5 to 55Hz(for 1min.) in each of X, Y, Z direction for 2 hours						
Relay life cycle	Mechanical	OUT1/2: Over 5,000,000 times, AL1/2: Over 20,000,000 times (TK4H/W/L: Over 5,000,000 times)					
	Electrical	OUT1/2: Over 200,000 times, AL1/2: Over 100,000 times (TK4H/W/L: Over 200,000 times)					
Insulation resistance	Min. 100MΩ (at 500VDC megger)						
Noise resistance	±2kV R-phase, S-phase the square wave noise (pulse width: 1us) by the noise simulator						
Memory retention	Approx. 10 years (when using non-volatile semiconductor memory type)						
Environment	Ambient temperature	-10 to 50 °C, storage: -20 to 60 °C					
	Ambient humidity	35 to 85%RH, storage: 35 to 85%RH					
Protection	IP65 (Front panel) ※TK4SP: IP50 (Front panel)						
Insulation type	Double insulation or reinforced insulation (Mark: □), Dielectric strength between the measuring input part and the power part: 2kV)						
Approval	CE cRU <sub>us</sub>						
Weight※2	Approx. 140g (Approx. 70g)	Approx. 130g (Approx. 85g)	Approx. 150g (Approx. 105g)	Approx. 210g (Approx. 140g)	Approx. 211g(Approx. 141g)	Approx. 294g (Approx. 198g)	

※1: ◎ At room temperature(23 °C±5°C)

- Thermocouple K, J, T, N, E type, below -100°C / Thermocouple L, U, PLII type, RTD(★) Cu50Q, DPt50Q : (PV ±0.3% or ±2°C, select the higher one) ±1digit
- Thermocouple C, G, R, S type, below 200 °C: (PV ±0.3% or ±3°C, select the higher one) ±1digit
- Thermocouple B type, below 400 °C: There is no accuracy standards.
- ◎ Out of room temperature range
  - RTD Cu50Q, DPt50Q: (PV ±0.5% or ±3°C, select the higher one) ±1digit
  - Thermocouple R, S, B, C, G type: (PV ±0.5% or ±5 °C, select the higher one) ±1digit
  - Others, Below -100°C: Within ±5°C

In case of TK4SP Series, ±1°C will be added to the degree standard.

※2: The weight is with packaging and the weight in parentheses is only unit weight.

※Environment resistance is rated at no freezing or condensation.

# High Accuracy Standard PID Control

## Connections

※Please check the polarity when connecting temperature sensor or analog input.

※Standard model has shaded terminals only.

(★)Operation mode of heating&cooling OUT2 relay output model is heating or cooling, OUT2 is available as alarm output 3. (except TK4N Series).

(★)Operation mode of heating&cooling OUT2 current output model is heating or cooling, OUT2 is available as transmission output 2.

### TK4N

#### Line-up

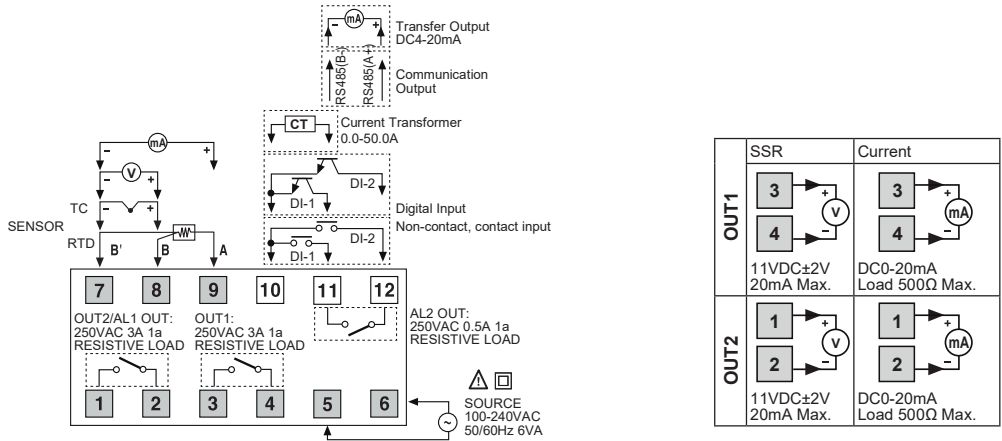

### TK4S

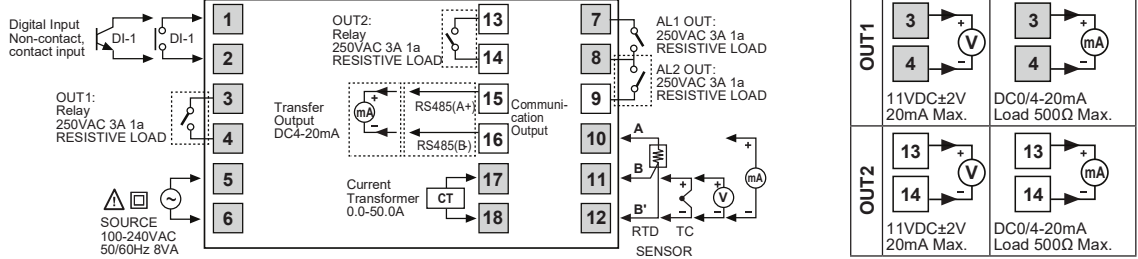

### TK4SP

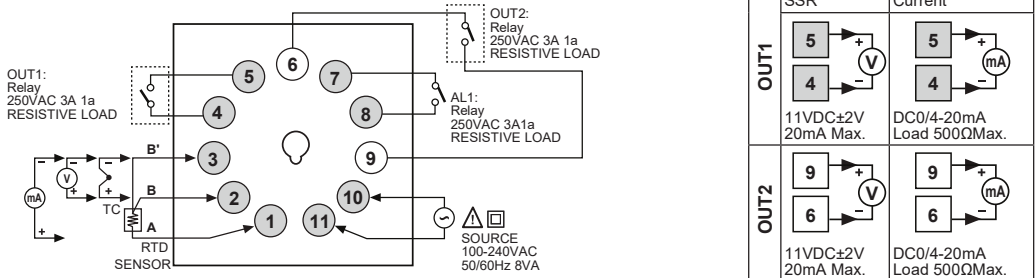

### TK4M

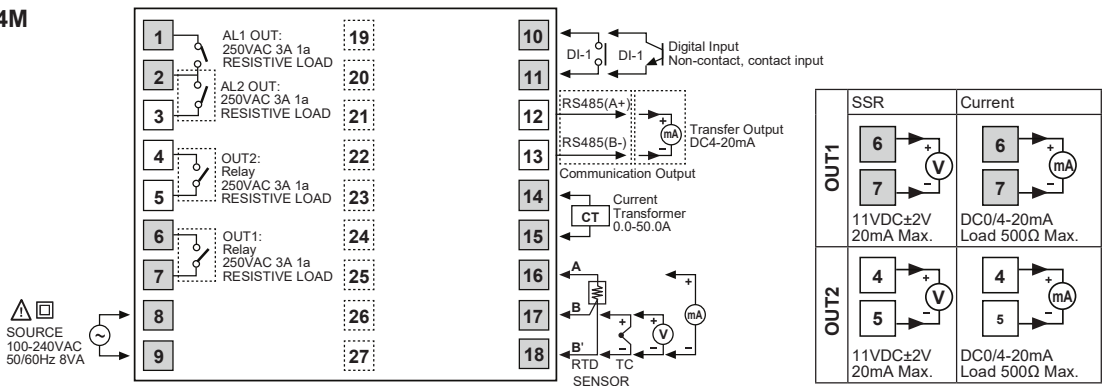

(A) Photo electric sensor

(B) Fiber optic sensor

(C) Door/Area sensor

(D) Proximity sensor

(E) Pressure sensor

(F) Rotary encoder

(G) Connector/Socket

(H) Temp. controller

(I) SSR/Power controller

(J) Counter

(K) Timer

(L) Panel meter

(M) Tacho/Speed/ Pulse meter

(N) Display unit

(O) Sensor controller

(P) Switching mode power supply

(Q) Stepper motor& Driver&Controller

(R) Graphic/Logic panel

(S) Field network device

(T) Software

(U) Other

# TK Series

## ■ Connections

※Please check the polarity when connecting temperature sensor or analog input.

※Standard model has shaded terminals only.

(★)Operation mode of heating&cooling OUT2 relay output model is heating or cooling, OUT2 is available as alarm output 3. (except TK4N Series).

(★)Operation mode of heating&cooling OUT2 current output model is heating or cooling, OUT2 is available as transmission output 2.

### ● TK4H / TK4W / TK4L

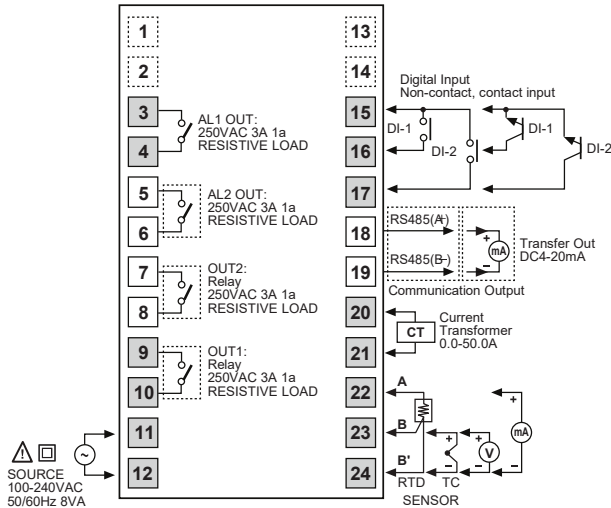

※Digital input is not electrically insulated from internal circuits, so it should be insulated when connecting other circuits. (Photocoupler, Relay, Independent switch)

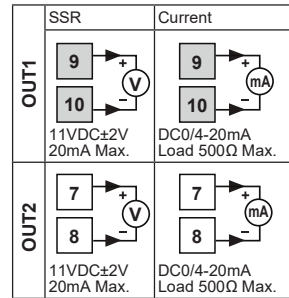

## ■ Dimensions

(unit: mm)

### ● TK4N

Line-up

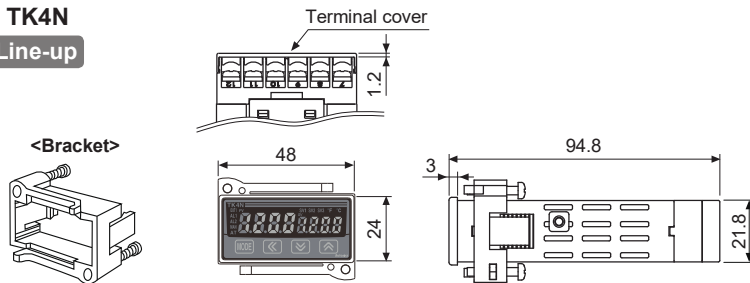

### ●Panel cut-out

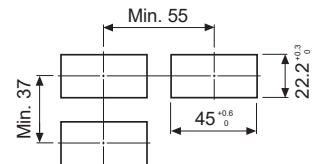

### ● TK4S

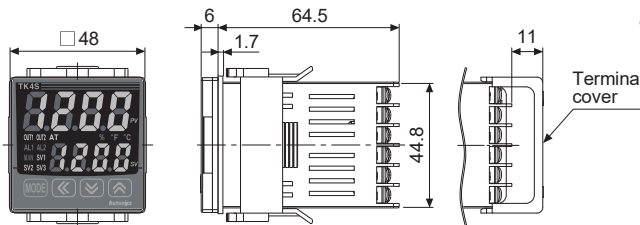
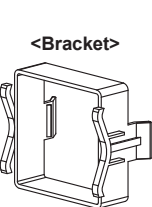

### ●Panel cut-out

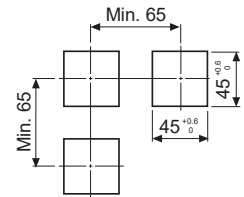

### ● TK4SP

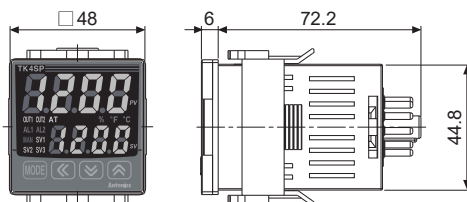
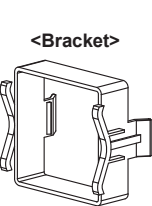

### ●Panel cut-out

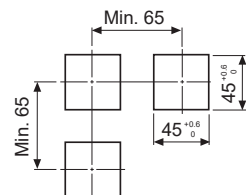

# High Accuracy Standard PID Control

## Dimensions

(unit: mm)

### TK4M

<Bracket>

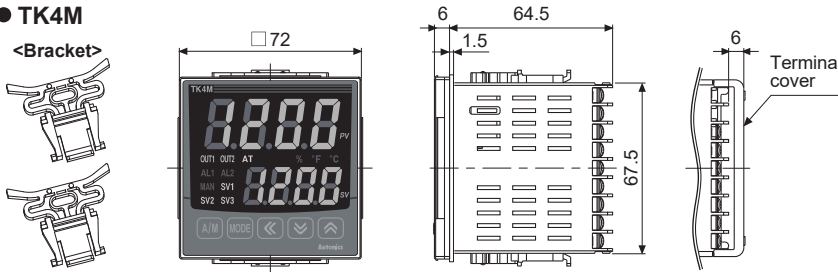

### Panel cut-out

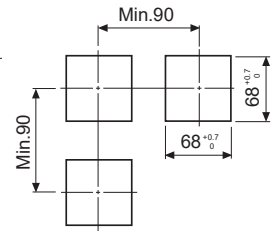

### TK4W

<Bracket>

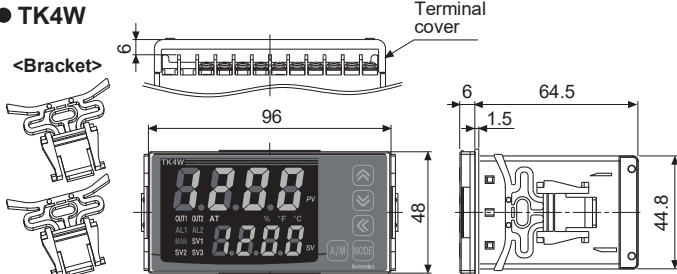

### Panel cut-out

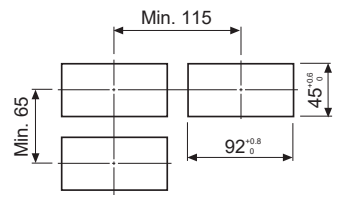

### TK4H

<Bracket>

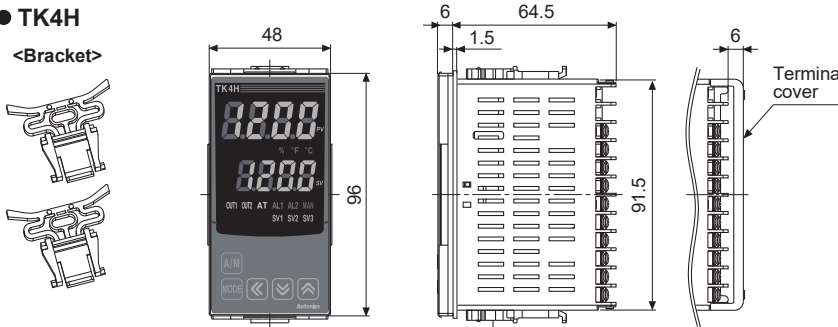

### Panel cut-out

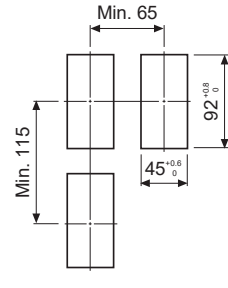

### TK4L

<Bracket>

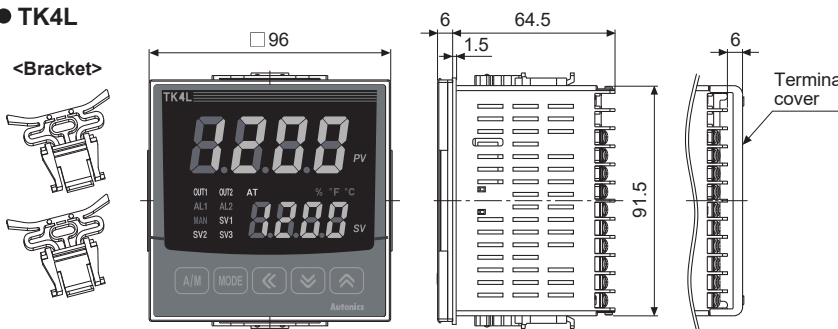

### Panel cut-out

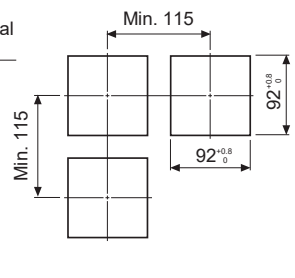

### Terminal cover(sold separately)

#### TK4N-COVER (48×24mm)

#### RSA-COVER (48×48mm)

#### RMA-COVER (72×72mm)

#### RHA-COVER (48×96mm, 96×48mm)

#### RLA-COVER (96×96mm)

Line-up

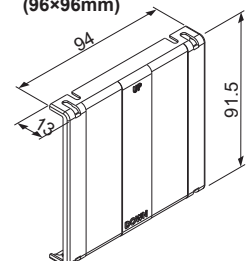
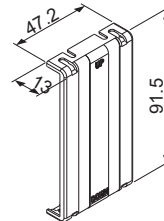
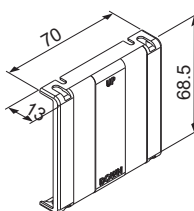
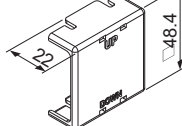
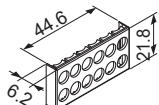

※TK4N cover is provided as an accessory.

(A)	Photo electric sensor
(B)	Fiber optic sensor
(C)	Door/Area sensor
(D)	Proximity sensor
(E)	Pressure sensor
(F)	Rotary encoder
(G)	Connector/Socket
(H)	Temp. controller
(I)	SSR/ Power controller
(J)	Counter
(K)	Timer
(L)	Panel meter
(M)	Tacho/ Speed/ Pulse meter
(N)	Display unit
(O)	Sensor controller
(P)	Switching mode power supply
(Q)	Stepper motor& Driver&Controller
(R)	Graphic/ Logic panel
(S)	Field network device
(T)	Software
(U)	Other

# TK Series

## Product mounting

### TK4N(48×24mm) Series

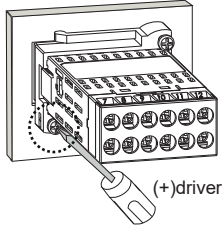

※ Insert the unit into a panel, fasten the bolt with a (+) driver.

### TK4S/SP(48×48mm) Series

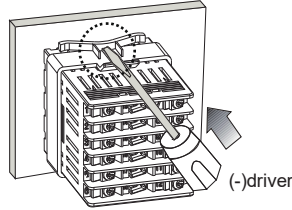

※ Insert the unit into a panel, fasten the bracket by pushing with tools with a (-) driver.

### Other Series

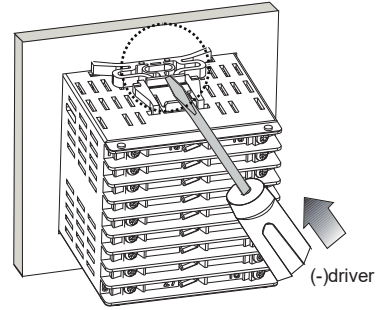

## Sold separately

### Communication converter

#### SCM-WF48 (available soon) (Wi-Fi to RS485/USB communication converter)



#### SCM-38I (RS232C to RS485 converter)



#### SCM-US48I (USB to RS485 converter)



#### SCM-US (USB to Serial converter)



### Current transformer(CT)

#### CSTC-E80LN

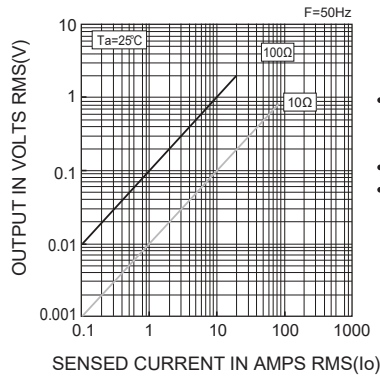
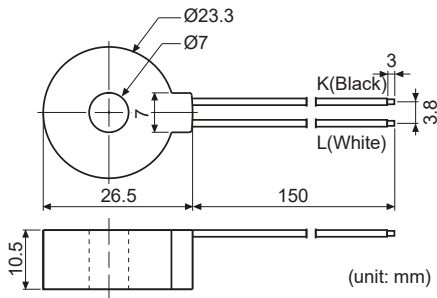

- Max. load current: 80A(50/60Hz)
- ※ Max. load current for TK4 Series is 50A.
- Current ratio: 1/1000
- Wire wounded resistance:  $31\Omega \pm 10\%$

#### CSTC-E200LN

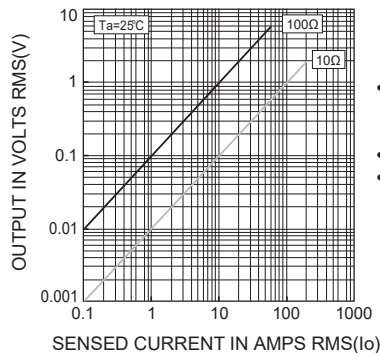
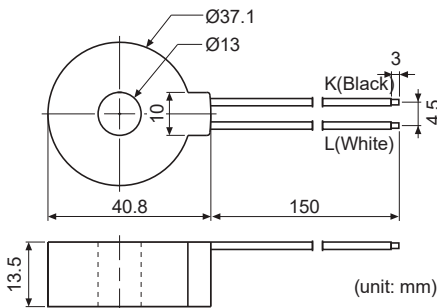

- Max. load current: 200A(50/60Hz)
- ※ Max. load current for TK4 Series is 50A.
- Current ratio: 1/1000
- Wire wounded resistance:  $20\Omega \pm 10\%$

※ Do not supply primary current in case that CT output is open. High voltage will be generated in CT output.

※ The current for above two CTs is 50A same but inner hole sizes are different. Please use this for your environment.

# High Accuracy Standard PID Control

## Parts description

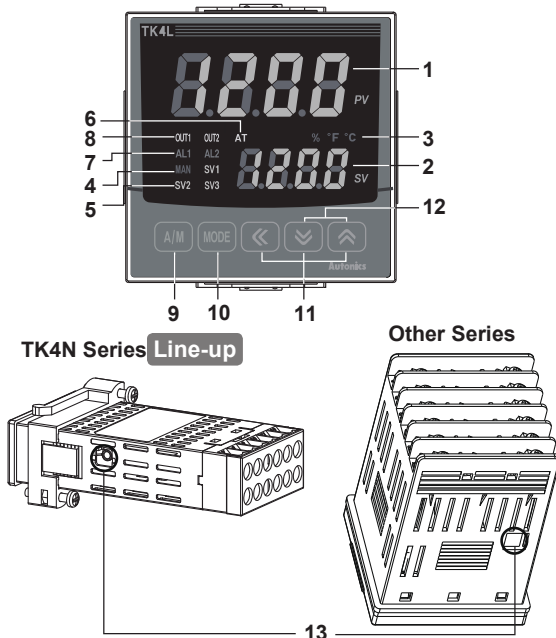

※The input selection switch (TC, RTD/mV, V, mA) switch disappears.  
Select input type [N-T] in parameter 3 group.

### The previous model

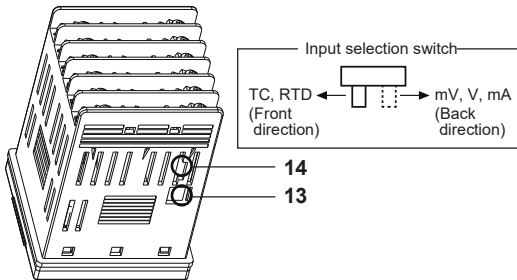

### 1. Measured value(PV) display part:

- RUN mode: It displays currently measured value (PV).
- Setting mode: It displays the parameter.

### 2. Set value (SV) display part:

- RUN mode: It displays the set value (SV).
- Setting mode: It displays the set value of the parameter.

### 3. Unit(°C / °F / %) Indicator: It displays the unit set at display unit [ UNT ] in parameter 3 group.

### 4. Manual control indicator: It turns ON during manual controlling.

### 5. Multi SV Indicator: One of SV1 to 3 lamp will be ON in case of selecting multi SV function.

### 6. Auto tuning indicator: It flashes by 1 sec. when executing auto tuning.

### 7. Alarm output (AL1, AL2) indicator: It turns ON when the alarm output is ON.

### 8. Control output (OUT1, OUT2) indicator: It turns ON when the control output is ON.

※During cycle/phase controlling in SSRP output type, when MV is over 5.0%, it turns ON.

※To use current output, when MV is 0.0% in manual control, it turns OFF. Otherwise, it always turns ON. When MV is over 3.0% in auto control, it turns ON and when MV is below 2.0%, it turns OFF.

### 9. A/M key: It is used when switching auto control to manual control.

※TK4N/S/SP do not have A/M key. MODE key operates switching simultaneously.

### 10. MODE key: It is used when entering parameter setting group, returning to RUN mode, moving parameter, saving the set value.

### 11. [Left], [Down], [Up] key: It is used when entering the set value changing mode and moving or changing up/down digit.

### 12. Digital input key: When pressing [Down] + [Up] keys for 3 sec. at the same time, it operates the function(RUN/STOP, alarm clear, auto tuning) set at digital input key [D1-K] in parameter 5 group.

### 13. PC loader port: It is the PC loader port for serial communication to set parameter and monitoring by DAQMaster installed in PC. Use this for connecting SCM-US(USB to Serial converter, sold separately).

### 14. Input selection switch: Used when switching sensor(TC, RTD) input ↔ analog input(mV, V, mA).(only the previous model)

## SV setting

You can set the temperature to control with [Left], [Down], [Up] keys.

Set range is within SV low-limit value [L-SV] to SV high-limit value [H-SV].

Ex) In case of changing set temperature from 210°C to 250°C

1 Press any key among [Left], [Down], [Up] key in RUN mode, the right digit at SV display flashes and it enters to SV setting.

2 Press [Left] key to move the desired digit.  
( $10^0 \rightarrow 10^1 \rightarrow 10^2 \rightarrow 10^3 \rightarrow 10^0$ )

3 Press [Down] or [Up] key to move the desired number (1 → 5).

4 Press [MODE] key to save the value and it controls with this set value. (even though there is no key input for over 3 sec., it saves automatically.)

(A)	Photo electric sensor
(B)	Fiber optic sensor
(C)	Door/Area sensor
(D)	Proximity sensor
(E)	Pressure sensor
(F)	Rotary encoder
(G)	Connector/Socket
(H)	Temp. controller
(I)	SSR/ Power controller
(J)	Counter
(K)	Timer
(L)	Panel meter
(M)	Tacho/ Speed/ Pulse meter
(N)	Display unit
(O)	Sensor controller
(P)	Switching mode power supply
(Q)	Stepper motor& Driver&Controller
(R)	Graphic/ Logic panel
(S)	Field network device
(T)	Software
(U)	Other



# TK Series

## Parameter group

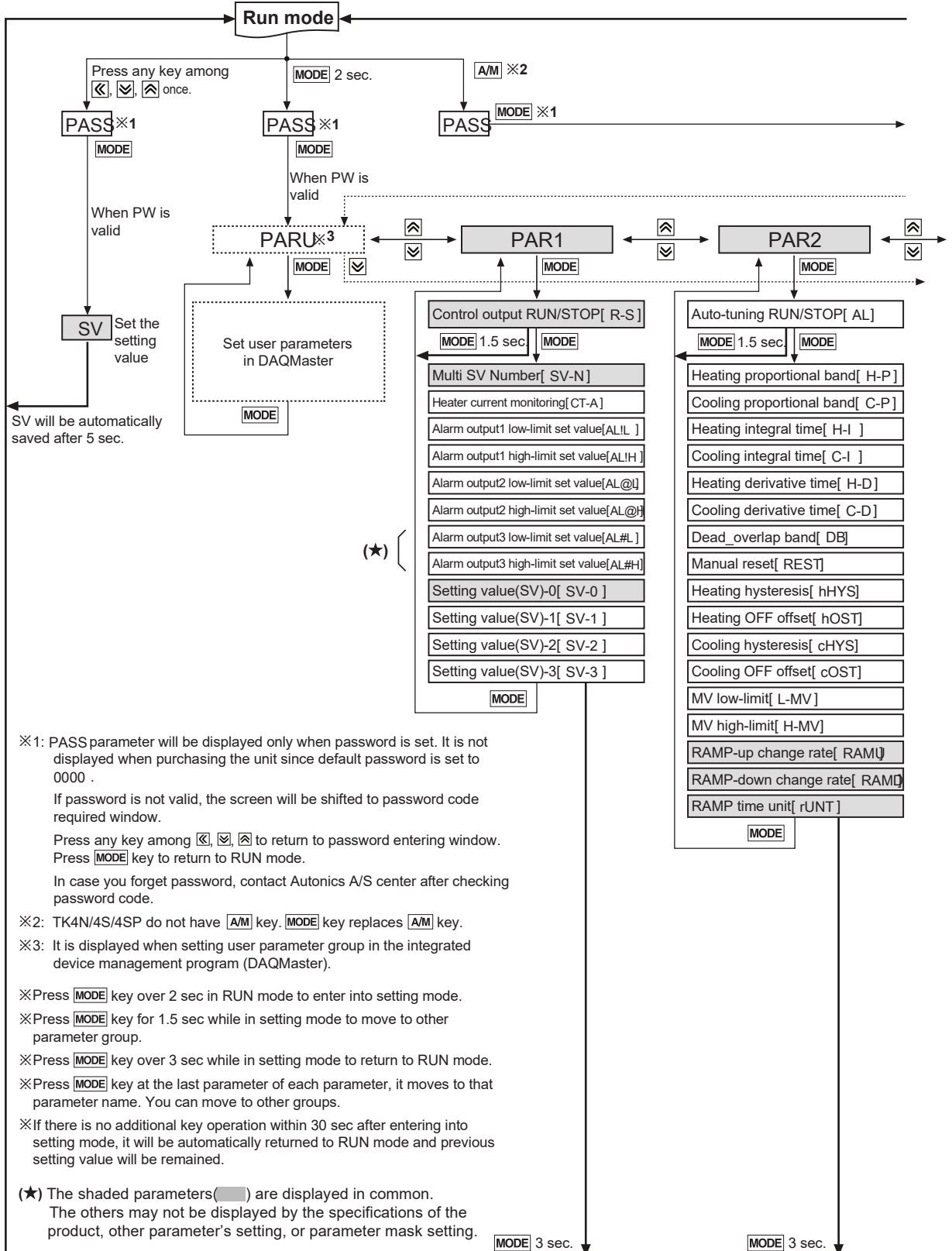

- ※1: PASS parameter will be displayed only when password is set. It is not displayed when purchasing the unit since default password is set to 0000 .  
If password is not valid, the screen will be shifted to password code required window.  
Press any key among  $\leftarrow$ ,  $\rightarrow$ ,  $\uparrow$  to return to password entering window.  
Press **MODE** key to return to RUN mode.  
In case you forget password, contact Autonics A/S center after checking password code.
- ※2: TK4N/4S/4SP do not have **A/M** key. **MODE** key replaces **A/M** key.
- ※3: It is displayed when setting user parameter group in the integrated device management program (DAQMaster).
- ※Press **MODE** key over 2 sec in RUN mode to enter into setting mode.
- ※Press **MODE** key for 1.5 sec while in setting mode to move to other parameter group.
- ※Press **MODE** key over 3 sec while in setting mode to return to RUN mode.
- ※Press **MODE** key at the last parameter of each parameter, it moves to that parameter name. You can move to other groups.
- ※If there is no additional key operation within 30 sec after entering into setting mode, it will be automatically returned to RUN mode and previous setting value will be remained.
- (★) The shaded parameters(■) are displayed in common.  
The others may not be displayed by the specifications of the product, other parameter's setting, or parameter mask setting.

# High Accuracy Standard PID Control

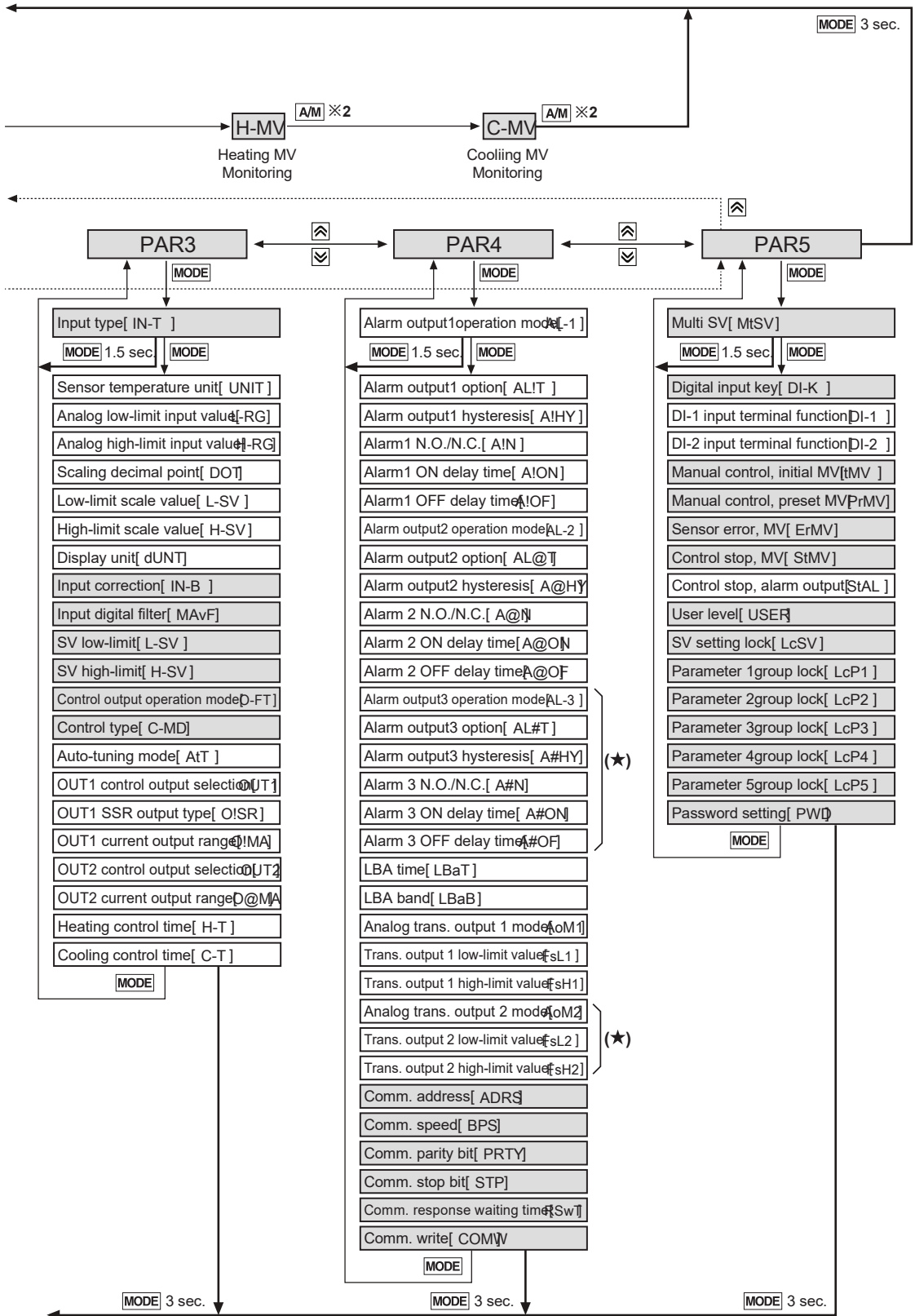

- (A) Photo electric sensor
- (B) Fiber optic sensor
- (C) Door/Area sensor
- (D) Proximity sensor
- (E) Pressure sensor
- (F) Rotary encoder
- (G) Connector/ Socket
- (H) Temp. controller
- (I) SSR/ Power controller
- (J) Counter
- (K) Timer
- (L) Panel meter
- (M) Tacho/ Speed/ Pulse meter
- (N) Display unit
- (O) Sensor controller
- (P) Switching mode power supply
- (Q) Stepper motor& Driver&Controller
- (R) Graphic/ Logic panel
- (S) Field network device
- (T) Software
- (U) Other

## Parameter 1 group

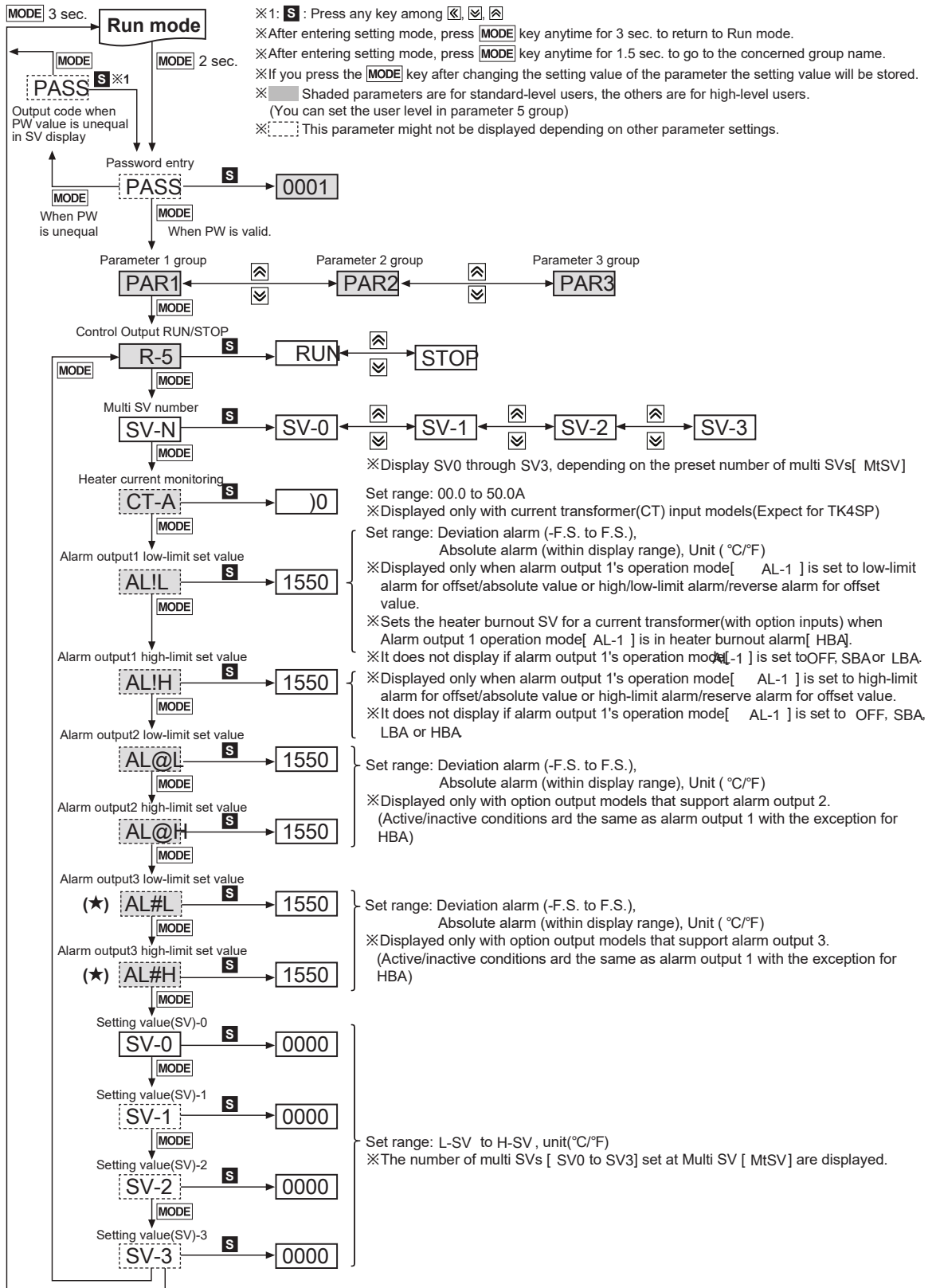

# High Accuracy Standard PID Control

## Parameter 2 group

※1: **S** : Press any key among , ,

※After entering setting mode, press **MODE** key anytime for 3 sec. to return to Run mode.

※After entering setting mode, press **MODE** key anytime for 1.5 sec. to go to the concerned group name.

※If you press the **MODE** key after changing the setting value of the parameter the setting value will be stored.

※ Shaded parameters are for standard-level users, the others are for high-level users.

(You can set the user level in parameter 5 group)

※ This parameter might not be displayed depending on other parameter settings.

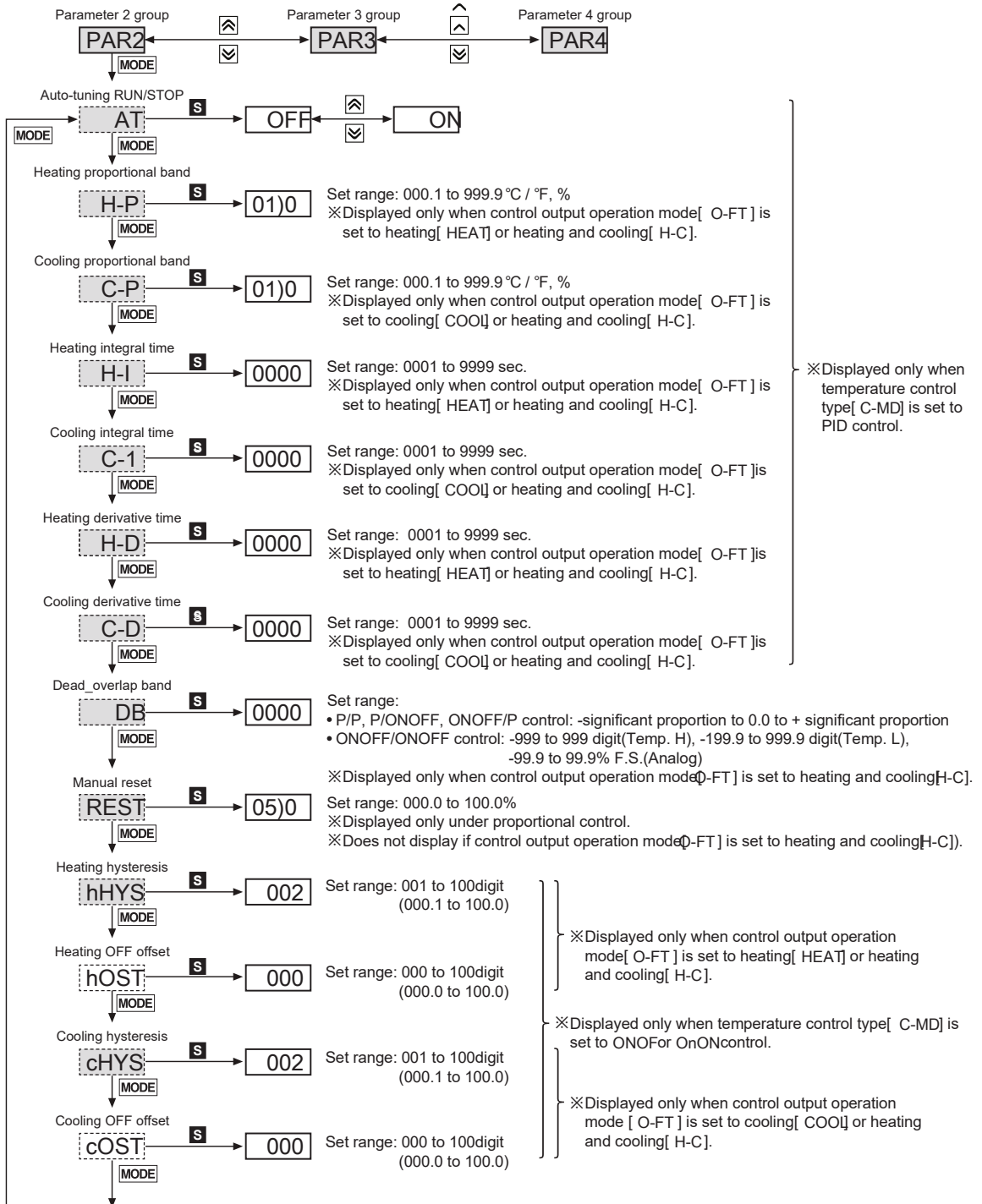

# TK Series

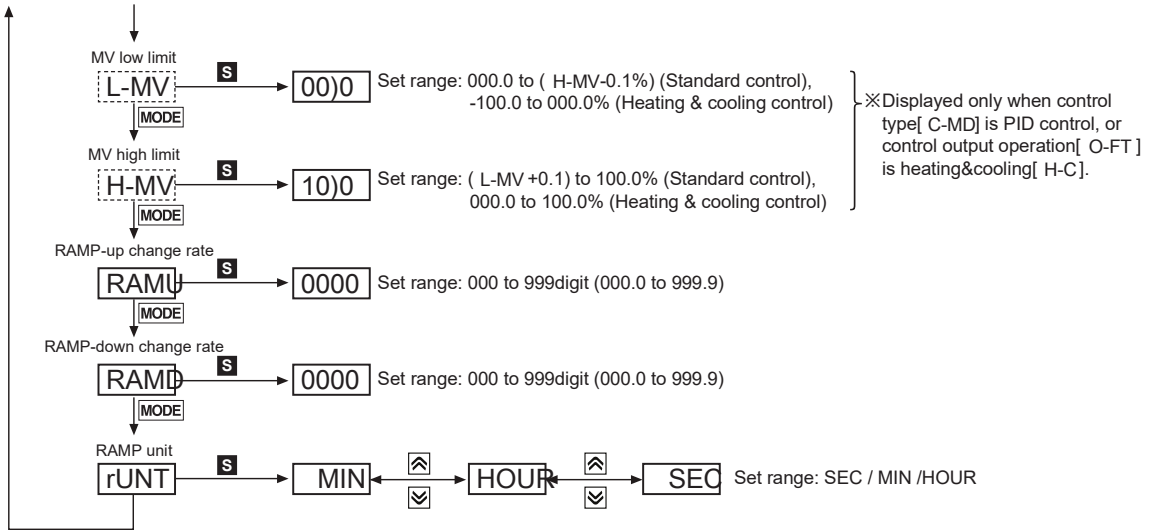

## Parameter 3 group

- ※1: **S** : Press any key among  $\leftarrow$ ,  $\rightarrow$ ,  $\uparrow$ ,  $\downarrow$
- ※After entering setting mode, press **MODE** key anytime for 3 sec. to return to Run mode.
- ※After entering setting mode, press **MODE** key anytime for 1.5 sec. to go to the concerned group name.
- ※If you press the **MODE** key after changing the setting value of the parameter the setting value will be stored.
- ※ Shaded parameters are for standard-level users, the others are for high-level users.  
(You can set the user level in parameter 5 group)
- ※: This parameter might not be displayed depending on other parameter settings.

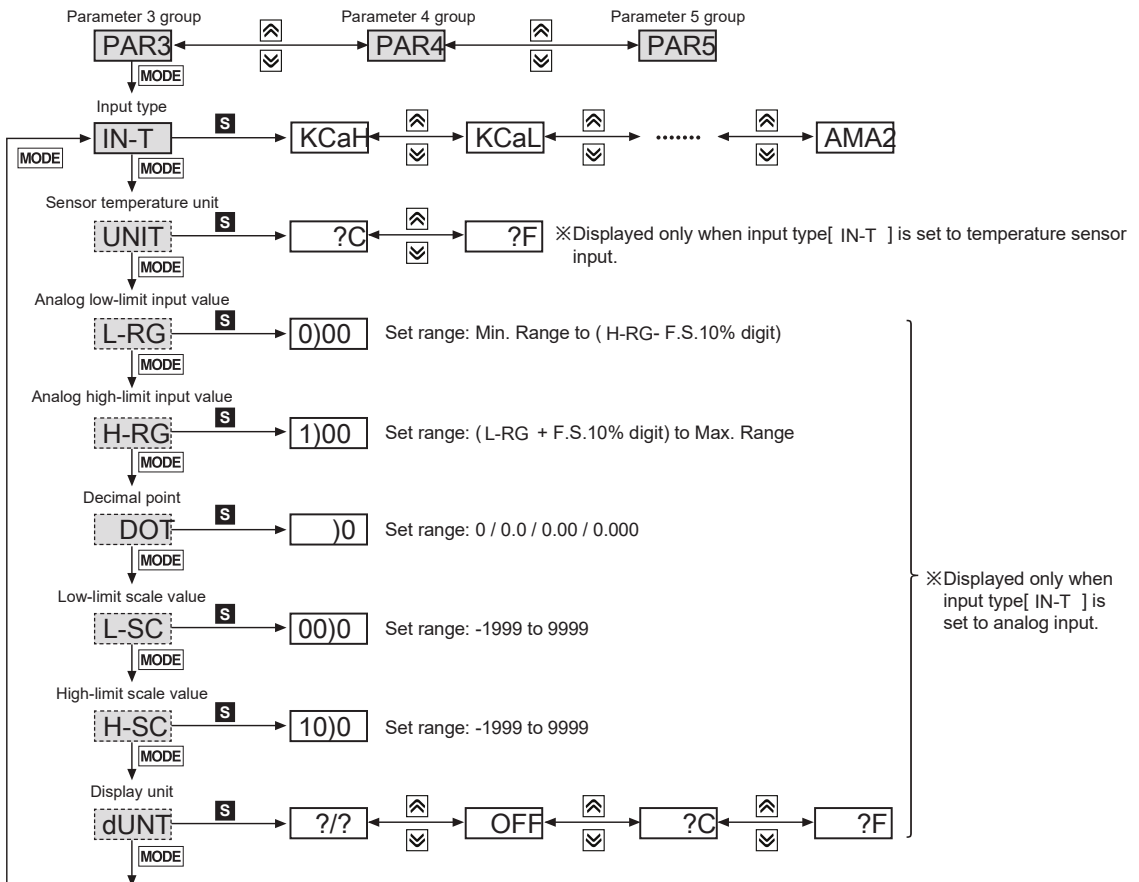

# High Accuracy Standard PID Control

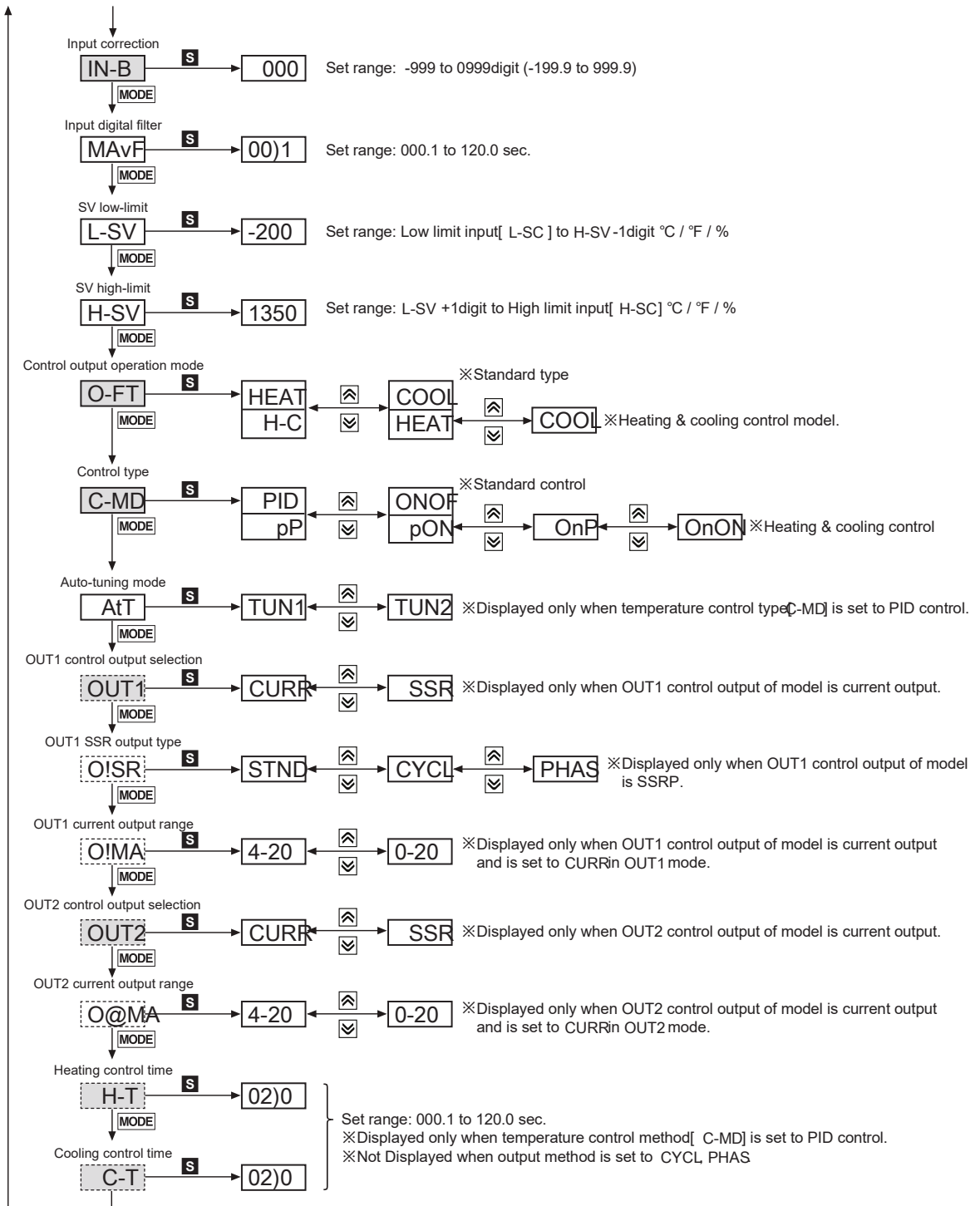



※OUT1, OUT2 output:

- In case that OUT1,OUT2 output is relay output type , OUT1, OISR, OIMA, OUT2, O@SRO@MA parameter are not displayed.
- In case that OUT1,OUT2 output is CUR + SSR output type, when OUT1,OUT2 output is set to SSR.
  - Output method of OISR, O@SRs held in STND and parameter is not displayed.
- In case that OUT1, output is SSRP output type and OUT2 output is SUR + SSR
  - OUT1, OIMA are not displayed.
  - OISR can set to STND, CYCL, PHAS
  - When O@SRs set to SSR it is held in STND and parameter is not displayed.

(A)	Photo electric sensor
(B)	Fiber optic sensor
(C)	Door/Area sensor
(D)	Proximity sensor
(E)	Pressure sensor
(F)	Rotary encoder
(G)	Connector/Socket
(H)	Temp. controller
(I)	SSR/ Power controller
(J)	Counter
(K)	Timer
(L)	Panel meter
(M)	Tacho/ Speed/ Pulse meter
(N)	Display unit
(O)	Sensor controller
(P)	Switching mode power supply
(Q)	Stepper motor& Driver&Controller
(R)	Graphic/ Logic panel
(S)	Field network device
(T)	Software
(U)	Other

## Parameter 4 group

※1: **S** : Press any key among , , 

※After entering setting mode, press **MODE** key anytime for 3 sec. to return to Run mode.

※After entering setting mode, press **MODE** key anytime for 1.5 sec. to go to the concerned group name.

※If you press the **MODE** key after changing the setting value of the parameter the setting value will be stored.

※  Shaded parameters are for standard-level users, the others are for high-level users.  
(You can set the user level in parameter 5 group)

※  This parameter might not be displayed depending on other parameter settings.

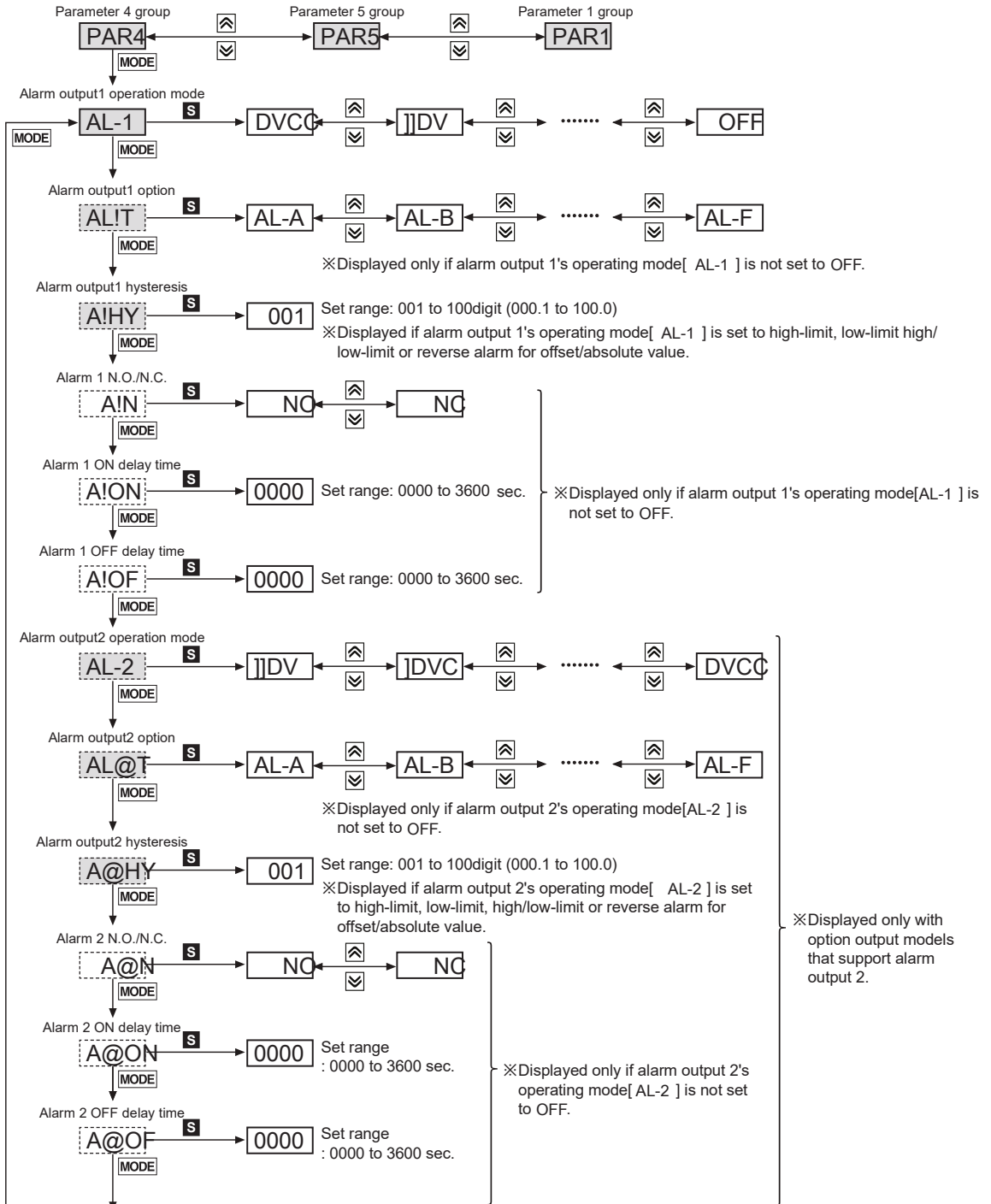

# High Accuracy Standard PID Control

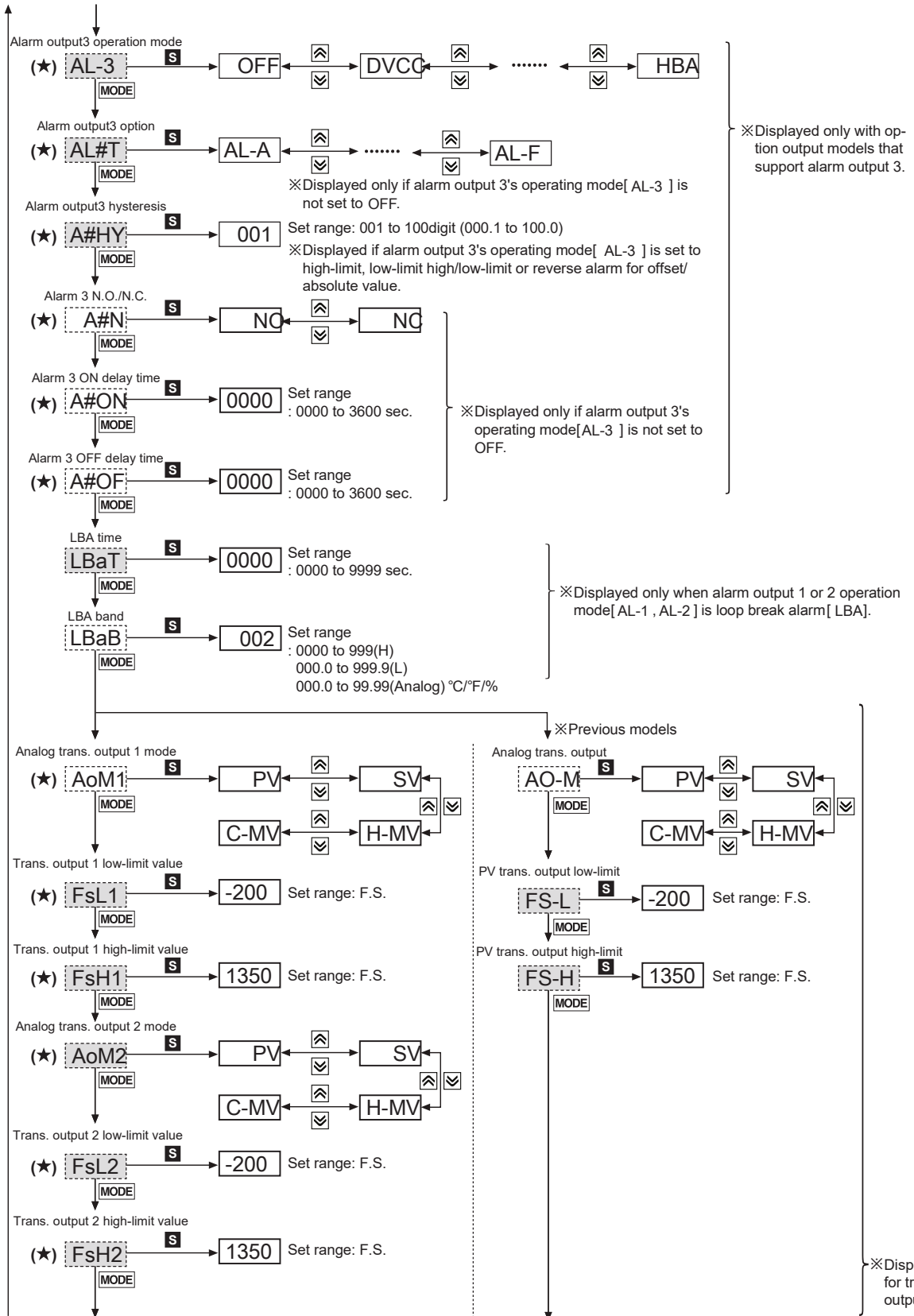



# TK Series

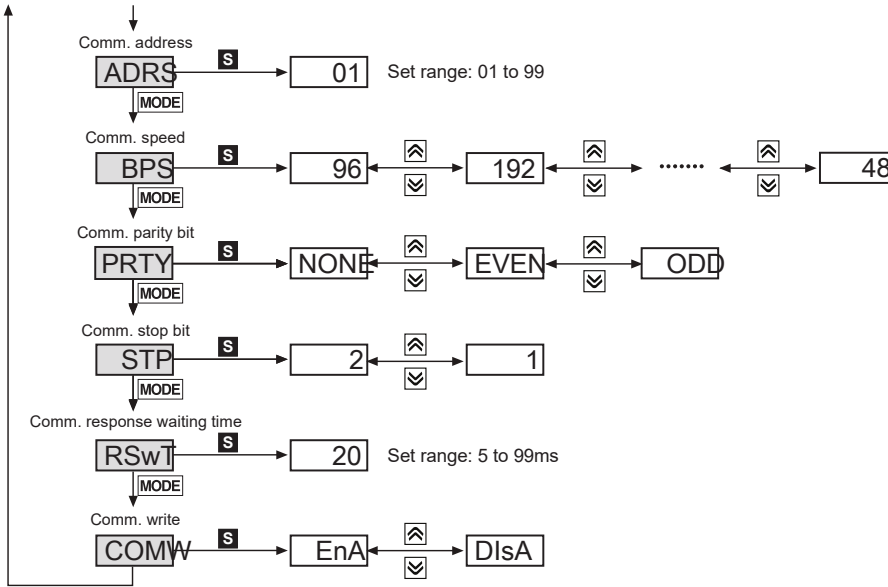

## Parameter 5 group

- ※1: **S**: Press any key among  $\leftarrow$ ,  $\rightarrow$ ,  $\uparrow$ ,  $\downarrow$ .
- ※After entering setting mode, press **MODE** key anytime for 3 sec. to return to Run mode.
- ※After entering setting mode, press **MODE** key anytime for 1.5 sec. to go to the concerned group name.
- ※If you press the **MODE** key after changing the setting value of the parameter the setting value will be stored.
- ※ Shaded parameters are for standard-level users, the others are for high-level users.  
(You can set the user level in parameter 5 group)
- ※: This parameter might not be displayed depending on other parameter settings.

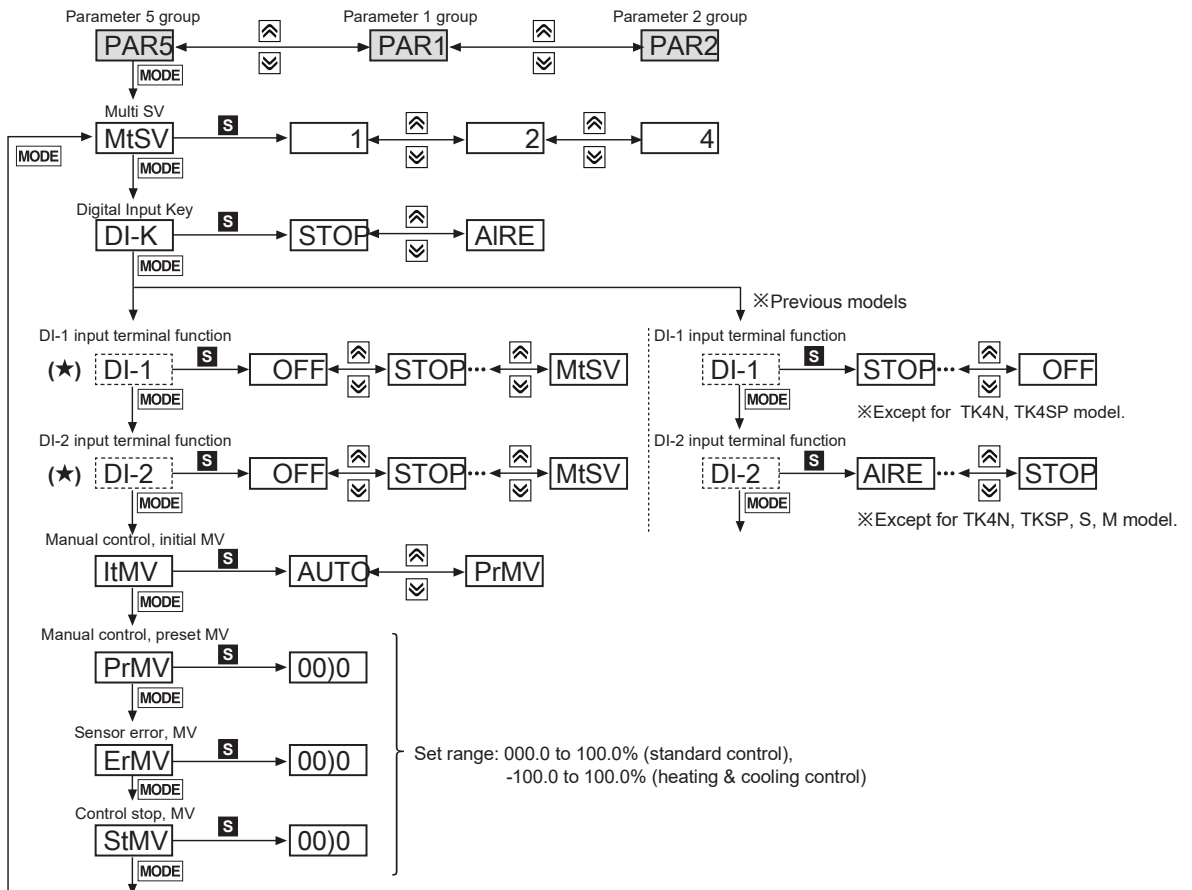

# High Accuracy Standard PID Control

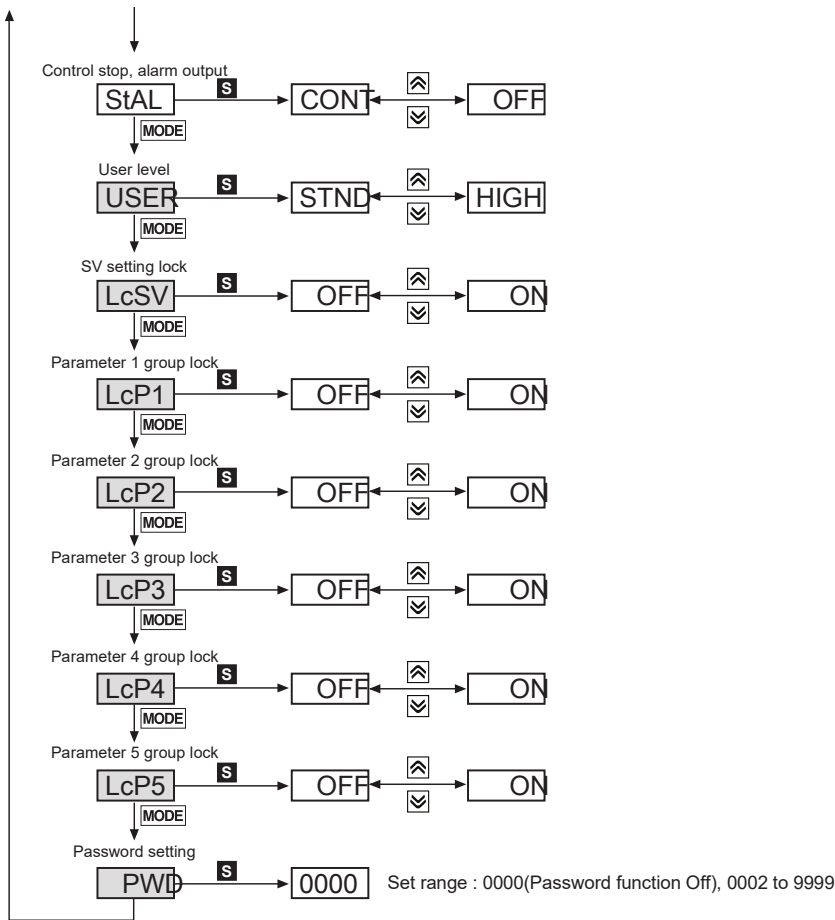

(A)	Photo electric sensor
(B)	Fiber optic sensor
(C)	Door/Area sensor
(D)	Proximity sensor
(E)	Pressure sensor
(F)	Rotary encoder
(G)	Connector/Socket
(H)	Temp. controller
(I)	SSR/ Power controller
(J)	Counter
(K)	Timer
(L)	Panel meter
(M)	Tacho/ Speed/ Pulse meter
(N)	Display unit
(O)	Sensor controller
(P)	Switching mode power supply
(Q)	Stepper motor& Driver&Controller
(R)	Graphic/ Logic panel
(S)	Field network device
(T)	Software
(U)	Other

## ■ Parameter Initialization

Press , , to initialize all parameters in memory to default value.

Set INIT parameter to YES to initialize all parameters.

In case password function is on, it is required to enter valid password to initialize parameters.

Password is also initialized.

# TK Series

## Input type and range

Input type		Decimal point	Display	Input range(°C)	Input range(°F)
Thermocouple	K(CA)	1	KCaH	-200 to 1350	-328 to 2463
		0.1	KCaL	-199.9 to 999.9	-199.9 to 999.9
	J(IC)	1	JlchH	-200 to 800	-328 to 1472
		0.1	JlclL	-199.9 to 800.0	-199.9 to 999.9
	E(CR)	1	ECrH	-200 to 800	-328 to 1472
		0.1	ECrL	-199.9 to 800.0	-199.9 to 999.9
	T(CC)	1	TCcH	-200 to 400	-328 to 752
		0.1	TCcL	-199.9 to 400.0	-199.9 to 752.0
	B(PR)	1	B PR	0 to 1800	32 to 3272
	R(PR)	1	R PR	0 to 1750	32 to 3182
	S(PR)	1	S PR	0 to 1750	32 to 3182
	N(NN)	1	N NN	-200 to 1300	-328 to 2372
	C(TT) <sup>※1</sup>	1	C TT	0 to 2300	32 to 4172
	G(TT) <sup>※2</sup>	1	G TT	0 to 2300	32 to 4172
	L(IC)	1	LlchH	-200 to 900	-328 to 1652
		0.1	LlclL	-199.9 to 900.0	-199.9 to 999.9
U(CC)	1	UCcH	-200 to 400	-328 to 752	
	0.1	UCcL	-199.9 to 400.0	-199.9 to 752.0	
Platinel II	1	PLII	0 to 1390	32 to 2534	
RTD	Cu 50Ω	0.1	CU 5	-199.9 to 200.0	-199.9 to 392.0
	Cu 100Ω	0.1	CU10	-199.9 to 200.0	-199.9 to 392.0
	JPt 100Ω	1	JPtH	-200 to 650	-328 to 1202
		0.1	JPtL	-199.9 to 650.0	-199.9 to 999.9
	DPt 50Ω	0.1	DPT5	-199.9 to 600.0	-199.9 to 999.9
	DPt 100Ω	1	DTtH	-200 to 650	-328 to 1202
		0.1	DPtL	-199.9 to 650.0	-199.9 to 999.9
	Nickel 120Ω	1	NI12	-80 to 200	-112 to 392
Analog	Voltage	0-10V	AV1	-1999 to 9999 (Display point will be changed according to decimal point position)	
		0-5V	AV2		
		1-5V	AV3		
		0-100mV	AMV1		
	Current	0-20mA	AMA1		
		4-20mA	AMA2		

※1: C(TT): Same as existing W5 (TT) type sensor

※2: G(TT): Same as existing W(TT) type sensor

## Front panel display when power is ON

When power is supplied, display will flash for 1 sec. Afterwards, model name and input sensor type will flash twice and then enter into RUN mode.

1. Whole display part

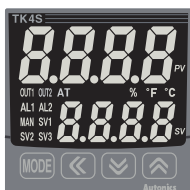

2. Model type display

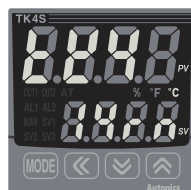

3. Input sensor type display



4. Run mode



# High Accuracy Standard PID Control

## ■ Factory default

### ● SV setting [SV]

Parameter	Factory default
SV	0

### ● Password input parameter

Parameter	Factory default
PASS	0001

### ● Parameter 1 group [PAR 1]

Parameter	Factory default	Parameter	Factory default	Parameter	Factory default	Parameter	Factory default
R-S	RUN	ALIH	1550	AL#H	1550	SV-3	0000
SV-N	SV-0	AL@L	1550	SV-0	0000	/	
CT-A	)0	AL@H	1550	SV-1	0000		
ALIL	1550	AL#L	1550	SV-2	0000		

### ● Parameter 2 group [PAR 2]

Parameter	Factory default	Parameter	Factory default	Parameter	Factory default	Parameter	Factory default
AT	OFF	H-D	0000	hOST	000	RAMU	000
H-P	01)0	C-D	0000	chYS	002	RAMD	000
C-P	01)0	DB	0000	cOST	000	rUNT	MIN
H-1	0000	REST	05)0	L-MV	)0)0	/	
C-1	0000	hHYS	002	H-MV	10)0		

### ● Parameter 3 group [PAR 3]

Parameter	Factory default	Parameter	Factory default	Parameter	Factory default	Parameter	Factory default
IN-T	KCaH	H-SC	10)0	O-FT	HEAT(standard)	OISR	STND
UNIT	><?C	dUNT	>?/O		H-C (heating & cooling)	OIMA	4-20
L-RG	0)00	IN-B	0000	C-MD	PID (standard)	OUT2	CURR
H-RG	1)00	MAvF	00)1		pP (heating & cooling)	O@MA	4-20
DOT	)0	L-SV	-200	AtT	TUN1	H-T	02)0 (relay) 00)0 (SSR drive)
L-SC	00)0	H-SV	1350	OUT1	CURR	C-T	

### ● Parameter 4 group [PAR 4]

Parameter	Factory default	Parameter	Factory default	Parameter	Factory default	Parameter	Factory default
AL-1	DVCC	A@N	NO	LBaT	0000	BPS	96
ALIT	AL-A	A@ON	0000	LBaB	002 (003 <sup>*1</sup> )	PRTY	NONE
AIHY	001	A@OF	0000	AoM1(AO-M <sup>*1</sup> )	PV	STP	2
AIN	NO	AL-3	OFF	FsL1 (FS-L <sup>*1</sup> )	-200	RSWT	20
AION	0000	AL#T	AL-A	FsH1 (FS-H <sup>*1</sup> )	1350	COMW	EnA
AIOF	0000	A#HY	001	AoM2	PV	/	
AL-2	]]DV	A#N	NO	FsL2	-200		
AL@T	AL-A	A#ON	0000	FsH2	1350		
A@HY	001	A#OF	0000	ADRS	01		

### ● Parameter 5 group [PAR 5]

Parameter	Factory default	Parameter	Factory default	Parameter	Factory default	Parameter	Factory default
MtSV	1	PrMV	00)0	LcSV	OFF	LcPS	OFF
DI-K	STOP	ErMV	00)0	LcP1	OFF	PWD	0000
DI-1	OFF(STOP <sup>*1</sup> )	StMV	00)0	LcP2	OFF	/	
DI-2	OFF(AIRE <sup>*1</sup> )	StAL	CONT	LcP3	OFF		
ItMV	AUTO	USER	STND	LcP4	OFF		

※ Shaded parameters are only for the new model.

※1: This parameter is for previous models.

(A) Photo electric sensor

(B) Fiber optic sensor

(C) Door/Area sensor

(D) Proximity sensor

(E) Pressure sensor

(F) Rotary encoder

(G) Connector/Socket

(H) Temp. controller

(I) SSR/ Power controller

(J) Counter

(K) Timer

(L) Panel meter

(M) Tacho/ Speed/ Pulse meter

(N) Display unit

(O) Sensor controller

(P) Switching mode power supply

(Q) Stepper motor & Driver & Controller

(R) Graphic/ Logic panel

(S) Field network device

(T) Software

(U) Other

# TK Series

## Alarm

### Alarm operation

Mode	Name	Alarm operation	Description
OFF	—	—	No alarm output
DVCC	Deviation high-limit alarm	 High deviation: Set as 10°C High deviation: Set as -10°C	If deviation between PV and SV as high-limit is higher than set value of deviation temperature, the alarm output will be ON.
]]DV	Deviation low-limit alarm	 Lower deviation: Set as 10°C Lower deviation: Set as -10°C	If deviation between PV and SV as low-limit is higher than set value of deviation temperature, the alarm output will be ON.
]DV[	Deviation high/low-limit alarm	 Lower deviation: Set as 10°C, High deviation: Set as 20°C High deviation: Set as 20°C	If deviation between PV and SV as high/low-limit is higher than set value of deviation temperature, the alarm output will be ON.
CDV]	Deviation high/low-limit reserve alarm	 Lower deviation: Set as 10°C, High deviation: Set as 20°C High deviation: Set as 20°C	If deviation between PV and SV as high/low-limit is higher than set value of deviation temperature, the alarm output will be OFF.
PVCC	Absolute value high limit alarm	 Absolute-value Alarm: Set as 90°C Absolute-value Alarm: Set as 110°C	If PV is higher than the absolute value, the output will be ON.
]]PV	Absolute value low limit alarm	 Absolute-value Alarm: Set as 90°C Absolute-value Alarm: Set as 110°C	If PV is lower than the absolute value, the output will be ON.
LBA	Loop break Alarm	—	It will be ON when it detects loop break.
SBA	Sensor break Alarm	—	It will be ON when it detects sensor disconnection.
HBA	Heater break alarm	—	It will be ON when CT detects heater break.

※ H: Alarm output hysteresis [ A□.HY ]

### Alarm option

Mode	Name	Description
AL-A	Standard alarm	If it is an alarm condition, alarm output is ON. If it is a clear alarm condition, alarm output is OFF.
AL-B	Alarm latch	If it is an alarm condition, alarm output is ON and maintains ON status.
AL-C	Standby sequence1	First alarm condition is ignored and from second alarm condition, standard alarm operates. When power is supplied and it is an alarm condition, this first alarm condition is ignored and from the second alarm condition, standard alarm operates.
AL-D	Alarm latch and standby sequence1	If it is an alarm condition, it operates both alarm latch and standby sequence. When power is supplied and it is an alarm condition, this first alarm condition is ignored and from the second alarm condition, alarm latch operates.
AL-E	Standby sequence2	First alarm condition is ignored and from second alarm condition, standard alarm operates. When re-applied standby sequence and if it is alarm condition, alarm output does not turn ON. After clearing alarm condition, standard alarm operates.
AL-F	Alarm latch and standby sequence2	Basic operation is same as alarm latch and standby sequence1. It operates not only by power ON/OFF, but also alarm setting value, or alarm option changing. When re-applied standby sequence and if it is alarm condition, alarm output does not turn ON. After clearing alarm condition, alarm latch operates.

※Condition of re-applied standby sequence for standby sequence 1, alarm latch and standby sequence 1: Power ON  
 Condition of re-applied standby sequence for standby sequence 2, alarm latch and standby sequence 2: Power ON, changing set temperature, alarm temperature[ AL1, AL2 ] or alarm operation[ AL-1, AL-2 ], switching STOP mode to RUN mode.

# High Accuracy Standard PID Control

## ■ Functions

### ◎ Parameter mask (★)

- This function is able to hide unnecessary parameters to user environment or less frequently used parameters in parameter setting group. You can set this in the integrated device management program (DAQMaster).
- Though masked parameters are not displayed in parameter setting group, the parameter setting values are applied. For more information, refer to the DAQMaster user manual.
- Visit our website ([www.autonics.com](http://www.autonics.com)) to download the DAQMaster program and the user manual.

※Ex) The above is masking auto tuning[AT], cooling proportional band[C-P], cooling integral time[C-1], cooling derivative time[C-D] parameters in parameter 2group.



※This function is for new model.

### ◎ User parameter group[PARU] setting (★)

- This function is able to set the frequently used parameters to the user parameter group. You can quickly and easily set parameter settings.
- User parameter group can have up to 30 parameters in the integrated device management program (DAQMaster).  
For more information, refer to the DAQMaster user manual.
- Visit our website ([www.autonics.com](http://www.autonics.com)) to download the DAQMaster program and the user manual.

Ex) The above is setting user parameter group in the DAQMaster with alarm output 1 low-limit value [AL1.L], alarm output 1 high-limit value [AL1.H], SV-0 set value [SV-0] parameter of parameter 1 group, heating hysteresis[hHYS], cooling hysteresis [cHYS] parameters of parameter 2 group, input correction[IN-B] parameter of parameter 3 group, alarm output 1 hysteresis [A1.HY], alarm output 2 hysteresis [A@HY] parameters of parameter 4 group.

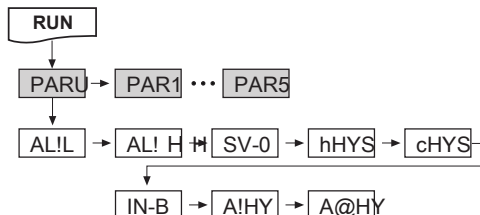

※This function is for new model.

### ◎ Auto tuning [AT]

In PID control, auto-tuning determines the control subject's thermal characteristics and thermal response rate, and then determines the necessary PID time constant. Application of the PID time constant realizes fast response and high precision temperature control.

- Auto-tuning automatically stores PID time constants upon termination. These PID time constants can then be modified by the user to suit their usage environment.
- When auto-tuning is in progress, the AT lamp located on the front of the controller flashes in 1 second intervals. When auto-tuning finishes, the AT lamp automatically goes off and the auto-tuning parameter will return to OFF.

Setting value	Descriptions
OFF	Auto tuning end
ON	Auto tuning run

Setting group	Parameter	Set range	Factory default	Unit
PAR2	AT	OFF/ ON	OFF	-

※Manual interruption or a sensor disconnection error when auto-tuning is in progress restores the PID time constant to the value used prior to the auto-tuning session.

※Auto-tuning continues to run even if the temperature reading exceeds or falls below the input range.

※When auto-tuning is in progress, parameters can only be referenced and not altered.

※Auto-tuning is not available in manual control.

### ◎ Control output operation mode [O-FT]

- Control output modes for general temperature control include heating, cooling, and heating and cooling.
- Heating control and cooling control are mutually opposing operations with inverse outputs.
- The PID time constant varies based on the controlled objects during PID control.

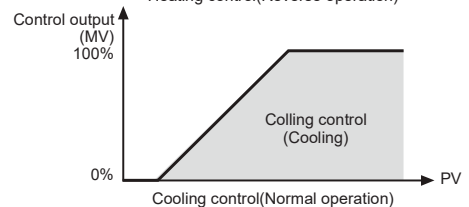
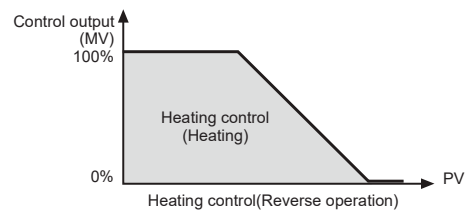

Setting group	Parameter	Set range	Factory default	Unit
PAR3	O-FT	Standard model HEAT COOL	HEAT	-
		Heating & Cooling model HEAT COOLH-C	H-C	-

(A) Photo electric sensor

(B) Fiber optic sensor

(C) Door/Area sensor

(D) Proximity sensor

(E) Pressure sensor

(F) Rotary encoder

(G) Connector/Socket

(H) Temp. controller

(I) SSR/Power controller

(J) Counter

(K) Timer

(L) Panel meter

(M) Tacho/Speed/Pulse meter

(N) Display unit

(O) Sensor controller

(P) Switching mode power supply

(Q) Stepper motor& Driver&Controller

(R) Graphic/Logic panel

(S) Field network device

(T) Software

(U) Other

# TK Series

## ⊙ Heating control [HEAT]

Heating control mode: the output will be provided in order to supply power to the load (heater) if PV (Present Value) falls below SV (Setting Value).

## ⊙ Cooling control [COOL]

Cooling control mode: the output will be provided in order to supply power to the load (cooler) if PV (Present Value) rises above SV (Setting Value).

## ⊙ Heating and cooling control [H-SC]

Heating and cooling control mode: heating and cooling with a single temperature controller when it is difficult to control subject temperature with only heating or cooling.

Heating and cooling control mode controls the object using different PID time constants for each heating and cooling.

It is also possible to set heating and cooling control in both PID control or ON/OFF control mode.

Heating/cooling output can be selected among Relay output, SSR output and current output depending on model types chosen according to your application environment.

(Note that only standard SSR control is available for SSR output in OUT2.)

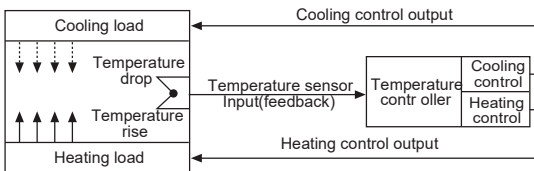

※For heating and cooling control, OUT1 control output is dedicated to heating control and OUT2 control output to cooling control.

## ⊙ Control output (OUT1/OUT2) selection [OUT1/OUT2]

In case of selecting the Models with current control output, both current and SSR outputs are available. You can therefore choose the right output type depending on application environments.

- OUT1: Selects OUT1 control output.
- OUT2: Selects OUT2 control output.

Setting group	Parameter	Set range	Factory default	Unit
PAR3	OUT1	SSR/ CURR	SSR	—
	OUT2			

## ⊙ For more information, refer to the user manual.

## ■ Proper usage

### ⊙ Simple "Error" diagnosis

#### ● When the load (Heater etc) is not operated

Please check operation of the OUT lamp located in front panel of the unit.

If the OUT lamp does not operate, please check the parameter of all programmed mode.

If lamp is operating, please check the output(Relay, SSR drive voltage) after separating output line from the unit.

#### ● When it displays *oPEn* during operation

This is a warning that external sensor is open.

Please turn off the power and check the wire state of the sensor. If sensor is not open disconnect sensor line from the unit and short the input +, - terminal. Turn on the power of the unit and check the controller displays room temperature.

If this unit cannot display room temperature, this unit is broken. Please remove this unit and contact our service center. (When the input mode is thermocouple, it is available to display room temperature.)

#### ● In case of indicating "Error" in display

This Error message is indicated in case of damaging inner chip program data by outer strong noise.

In this case, please send the unit to our after service center after removing the unit from system.

Noise protection is designed in this unit, but it does not stand up strong noise continuously. If bigger noise than specified(Max. 2kV) flows in the unit, it can be damaged.

### ⊙ Caution for using

- Please use separated line from high voltage line or power line in order to avoid inductive noise.
- Please install power switch or circuit-breaker in order to cut power supply off.
- The switch or circuit-breaker should be installed near by users.
- This unit is designed for temperature controlling only. Do not apply this unit as a voltage meter or a current meter.
- In case of using RTD sensor, 3-wire type must be used. If you need to extend the line, 3-wires must be used with the same thickness as the line. It might cause temperature difference if the resistance of line is different.
- In case of making power line and input signal line close, line filter for noise protection should be installed at power line and input signal line should be shielded.
- Keep away from the high frequency instruments.(High frequency welding machine & sewing machine, big capacitive SCR controller)
- Installation environment
  - It shall be used indoor.
  - Altitude Max. 2000m.
  - Pollution Degree 2
  - Installation Category II.